

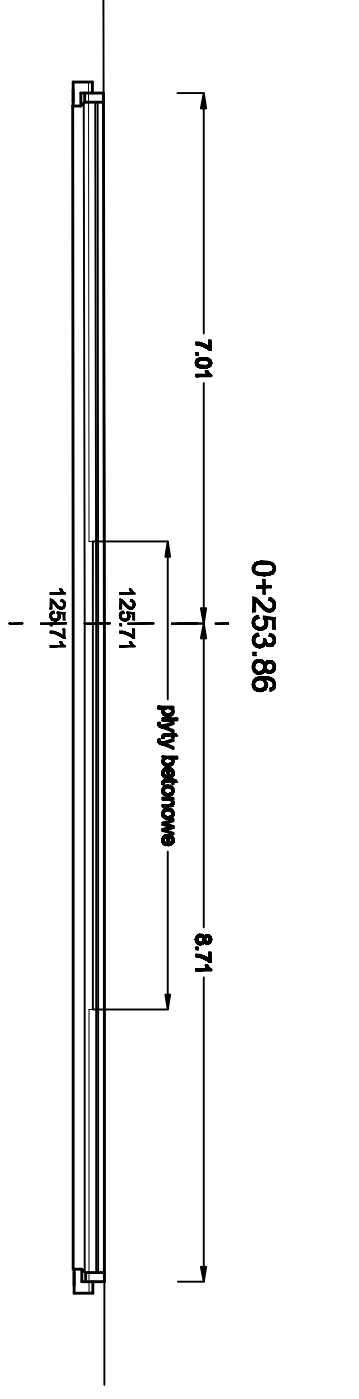

# Warmińska

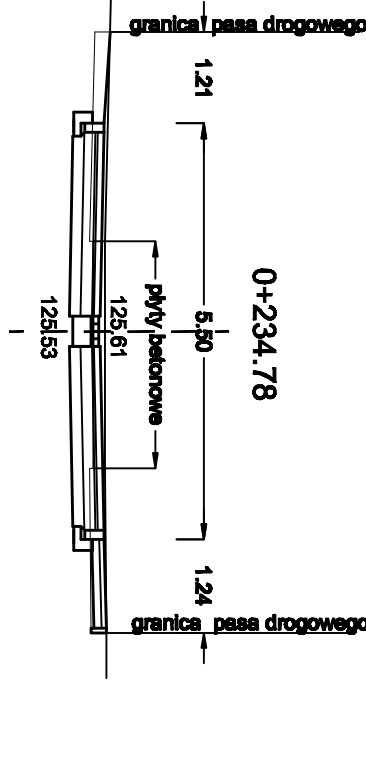
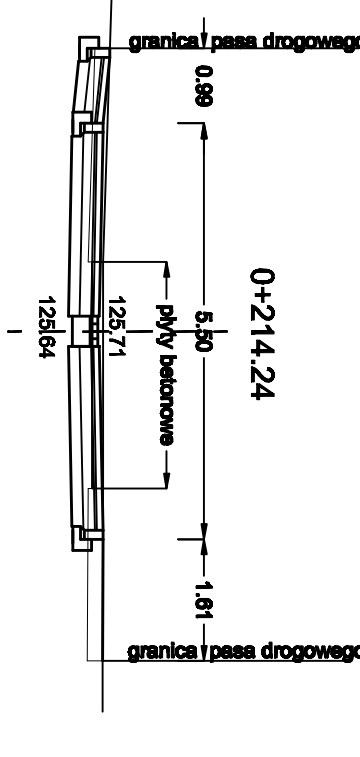
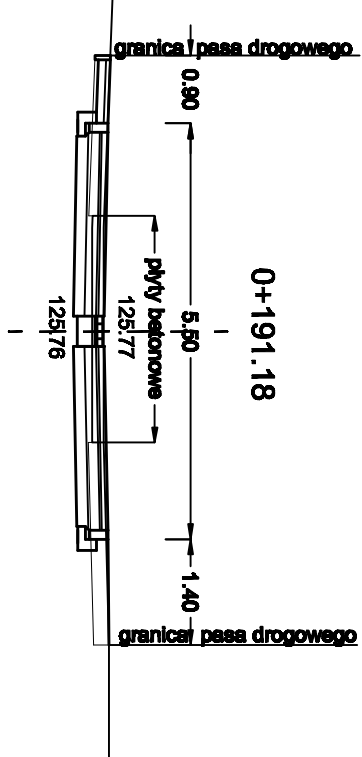
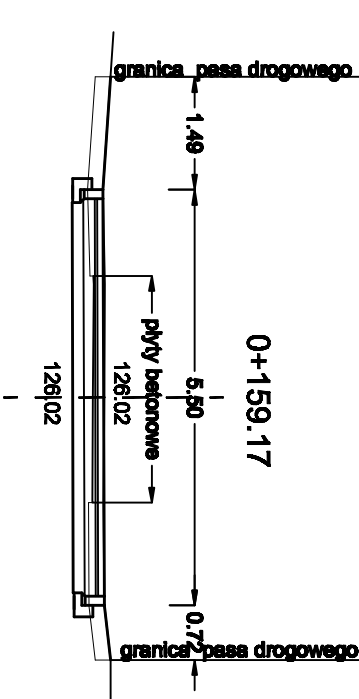
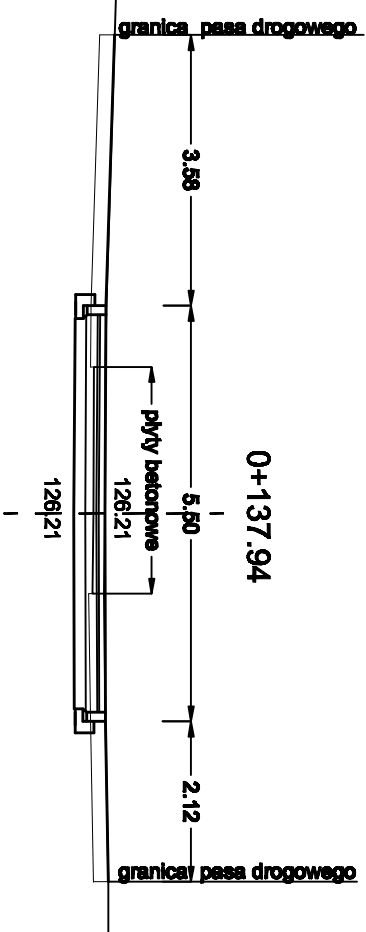
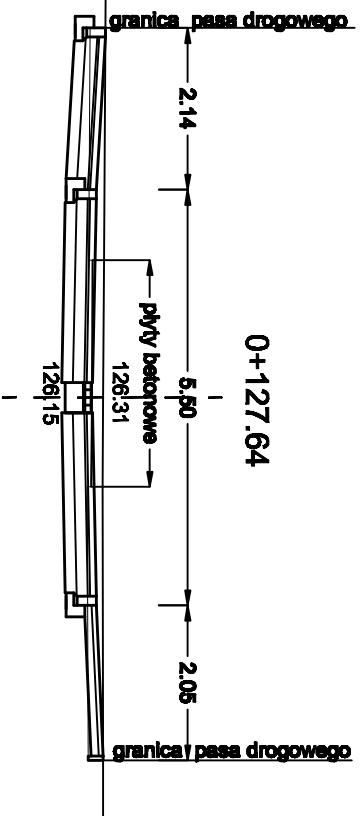
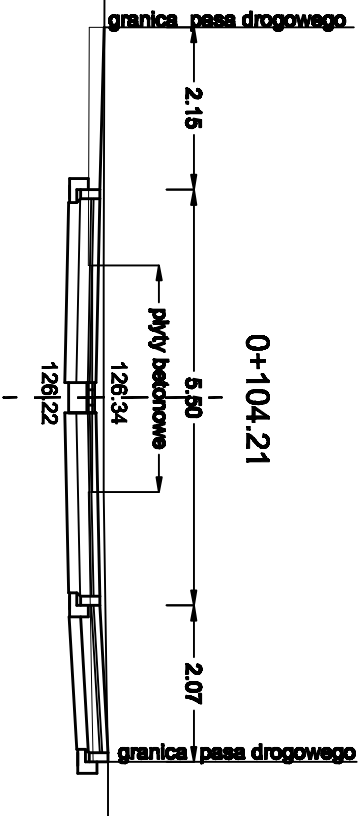
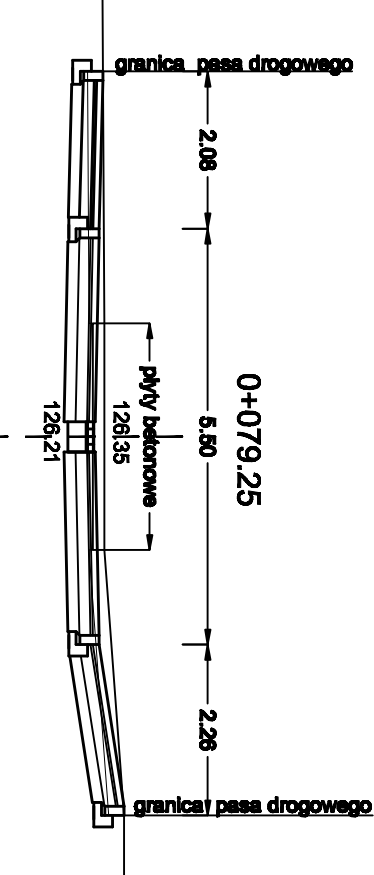
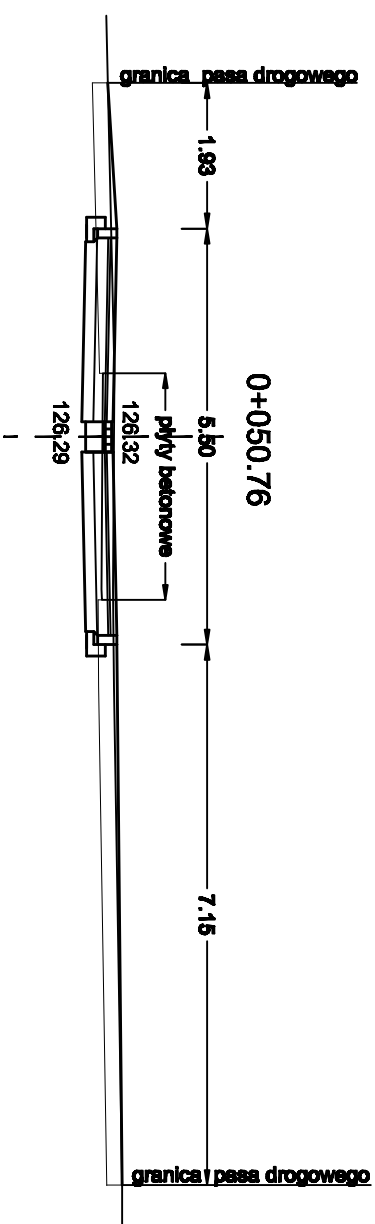
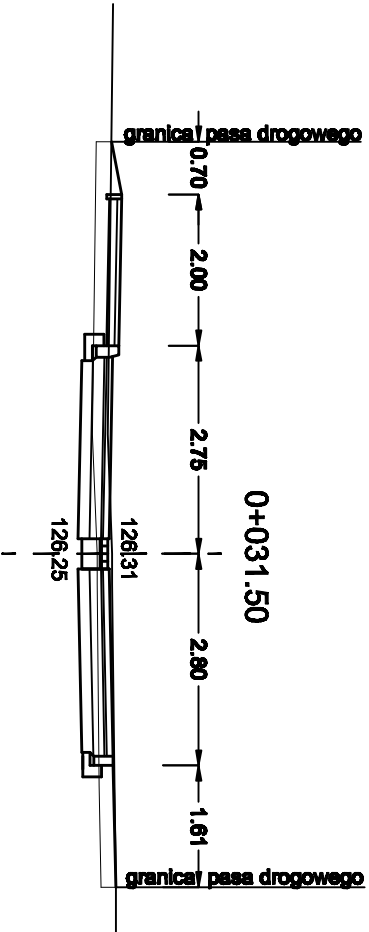
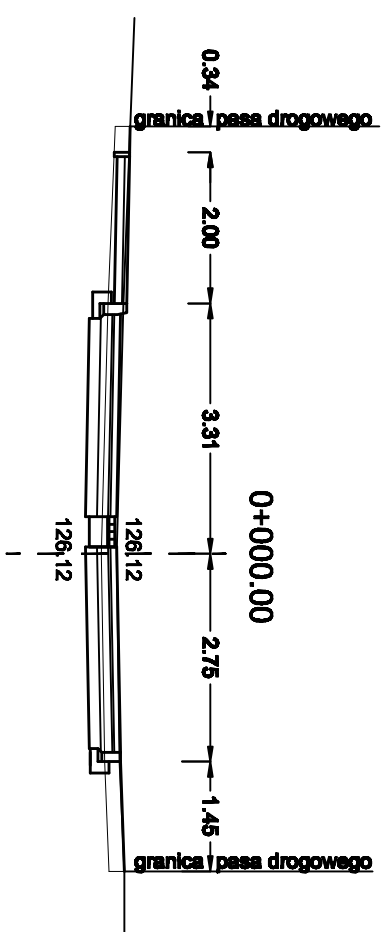

<b>Investor:</b>		<b>Miejski Zarząd Dróg w Ostrowie Wielkopolskim</b>	
		ul. Zamieszkała 2b, 63-400 Ostrow Wielkopolski	
		<b>Pracownia Projektowa Sieci i Instalacji Sanitarnych</b>	
ul. Słowackiego 1a, 63-400 Ostrow Wielkopolski		ul. Słowackiego 1a, 63-400 Ostrow Wielkopolski	
<b>OBIEKT:</b>		<b>Przebudowa ulic Mazurskiej i Warmińskiej w Ostrowie Wielkopolskim</b>	
<b>Miejscowość:</b>		<b>Ostrow Wielkopolski</b>	
<b>Przebieg poprzeczny</b>		<b>Data opracowania: 10.2015</b>	
<b>Temat:</b>	<b>Funkcja</b>	<b>Nazwisko, Imię</b>	<b>Nr uprawnień</b>
<b>Brandza</b>	<b>Projektant</b>	<b>mgr inż. Michał Józwiak</b>	<b>7131/134/P/2001</b>
<b>drogi</b>	<b>Opracował</b>	<b>mgr inż. Małgorzata Józwiak</b>	
<b>drogi</b>			